

# Study and Analysis of a Bi-directional Radio with Fiber Multiplexing System for Communication Services

Satbir Singh<sup>1\*</sup>, Shashi B. Rana<sup>2</sup> and Saurabh Kher<sup>3</sup>

<sup>1,2,3</sup>Dept. of Electronics Technology

Guru Nanak Dev University, Regional Campus, Gurdaspur, Punjab, India  
e-mail: satbir1\_78@yahoo.co.in

**Abstract**– Radio with fiber technology is used widely for the distribution of microwave signals for coverage and capacity at medium to longer distance. In this paper, a simulation-based approach for design and analysis of a 10GHz bi-directional radio over fiber multiplexing communication system has been achieved at a bit rate of 10Gbps for broadband communication services like cellular, cable television (CATV) and Wi-Fi system. Furthermore, it has been investigated that with increasing the distance covered by the optical fiber, between the central station and the base station, the performance of the resultant RF signal degraded. The BER and quality factor of the RoF system decreases for a fixed number of channels (N=80). The maximum achieved value of the Q-factor for uplink connection is 9.60 dB and its minimum achieved value for downlink connection is 8.32dB at a fiber length of 2 Km. The bit error rates for uplink and downlink connections at an optical distance of 11 km remains same. The net loss measured for the received power level is 8.79dBm. Further, it has been investigated that the dispersion of single mode fiber has significant impact on the performance of RoF system. The Q-factor value of 8.91 dB has been achieved at dispersion level of 16.75ps/nm/km for RoF system.

**Index Terms** – RoF, Sub-Carriers, RAU, Sub-Carrier Multiplexing Radio over Fiber System, IM-DD, BER, Q-factor etc.

## 1 INTRODUCTION

Radio with fiber technology uses the optical fiber links to distribute RF or microwave signals from a central location (head end) to Remote Antenna Units (RAUs) [1, 2]. RoF makes it possible to centralizes the RF signal processing functions in a head end and then to use optical fiber, which offers low signal loss (0.3 dB/km for 1550 nm, and 0.5 dB/km for 1310 nm wavelengths) to distribute the RF signals to the RAUs, as shown in figure 1.1. The centralization of RF signal processing functions enables equipment sharing, dynamic allocation of resources, simplified system operation and maintenance.

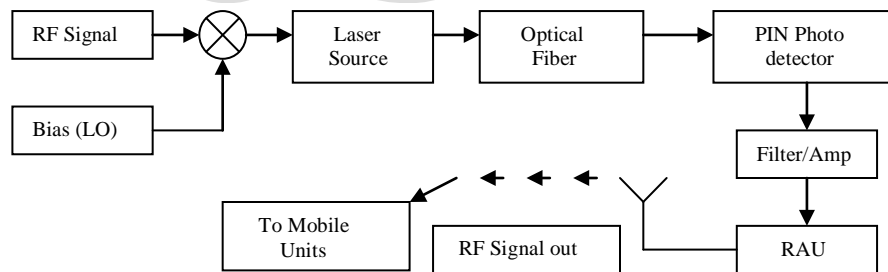

Fig 1.1 Basic radio over fiber communication System

Such a RoF system may be used to distribute GSM signals [3, 4] in communication applications, such as CATV, Wi-Fi, 3G etc. RoF technology is generally unsuitable for system applications, where high Spurious Free Dynamic Range (SFDR) is required, because of the limited DR. This is especially true of wide coverage mobile systems such as GSM, where SFDR > 70 dB (outdoor) are required. However, most indoor applications do not require high SFDR. For instance, the required (uplink) SFDR for GSM reduces from >70 dB to about 50 dB for indoor applications. Therefore, RoF distribution systems can readily be used for in-building (indoor) distribution of wireless signals of both mobile, TV and data communication systems.

This system distribute the base band signals or signals at low intermediate frequencies (IF) from the switching centre (head end) to the BS. The base band or IF signals are up-converted to the required microwave or mm-wave frequency at each base station, amplified and then radiated [5,6]. The RF signal is used to directly modulate the laser diode in the central site (head end). The resulting intensity modulated optical signal is then transported over the length of the fiber to the base station (RAU). At the RAU, the transmitted RF signal is recovered by direct detection in the PIN photo detector. The signal is then amplified and radiated by the antenna. The uplink signal from the mobile unit is transported from the RAU to the head end in the same way. This method of transporting RF signals over the fiber is called Intensity Modulation with Direct Detection (IM-DD) [8, 9]. There

are two ways of modulating the light source as shown in figure 1.2. One way is to let the RF signal directly modulate the laser diode's current. The second option is to operate the laser in continuous wave (CW) mode and then use an external modulator such as the Mach-Zehnder Modulator (MZM), to modulate the intensity of the light.

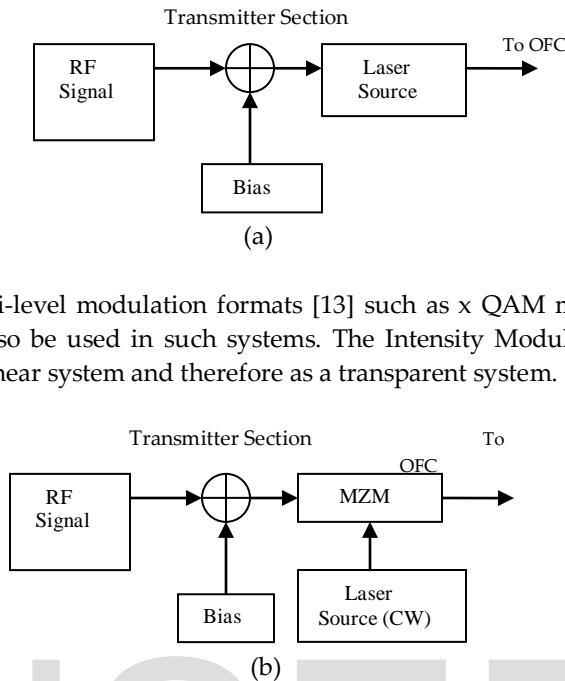
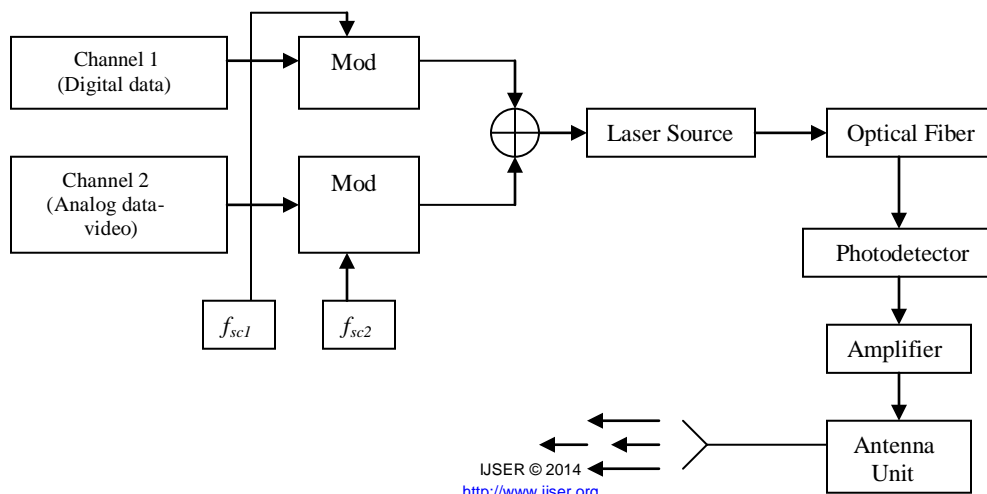

Fig 1.2 RF signal generation by Intensity Modulation  
 (a) Direct modulation of Laser  
 (b) External modulation

The advantage of IM-DD method is simplicity and low cost. Moreover, if low dispersion fiber is used in conjunction with an appropriate choice of laser's operating parameter the system becomes quasi linear. This can be achieved by using low dispersion fiber (SMF) in combination with pre-modulated RF sub-carriers (SCs) [12]. The motivation of such type of the simulation work will enhance application aspects of the optical fiber technology in the service of mankind. The future communication models of radio over fiber technology will be more effective and cheaper with high signal quality rates. In the following section, we will discuss about RoF multiplexing method and its utilization in the simulative work.

## 2 RADIO OVER FIBER MULTIPLEXING METHOD

The Sub-carrier Multiplexing (SCM) technique [11] is a maturing simple and cost effective approach for exploiting optical fiber bandwidth in analog optical communication systems and in RoF systems. In SCM, an RF or microwave signal (the sub-carrier) is used to modulate an optical carrier at the transmitter's side (shown in figure 2.1).



RF signals ( $f_{sc1}, f_{sc2}$ )

Fig 2.1 Sub-carrier Multiplexing (SCM) of mixed Digital and Analog Signals in Radio over Fiber System.

This result in an optical spectrum consisting of the original optical carrier  $f_0$ , plus two side-tones located at  $f_0 \pm f_{sc}$  where  $f_{sc}$  is the sub-carrier frequency. If the sub carrier itself is modulated with data (analog or digital), then sidebands centered on  $f_0 \pm f_{sc}$  are produced as shown in figure 2.2. To multiplex multiple channels on to one optical carrier, multiple sub carriers are first combined and then used to modulate the optical carrier as shown in figure 2.1. At the receiver's side the sub carriers are recovered through direct detection and then radiated. The mobile station is tuned to select and receive the desired sub-carrier(s), which may then undergo down conversion and appropriate demodulation. Different modulation schemes may be used on the different sub carriers.

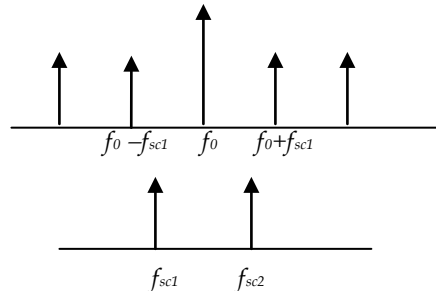

Fig 2.2 Optical Spectrum of sub-carriers

One sub carrier may carry digital data, while another may be modulated with an analog signal such as video or telephone traffic. In this way, SCM supports the multiplexing of various kinds of mixed mode broadband data. Modulation of the optical carrier may be achieved by either directly modulating the laser or by using external modulators such as the MZM. Sub carrier multiplexing (SCM) may be used in both IM-DD and RHD radio over fiber methods [14, 15]. The following section focuses upon the set up of bi-directional radio over fiber communication system with results.

### 3 SIMULATIVE SET UP FOR BI-DIRECTIONAL RADIO OVER FIBER COMMUNICATION SYSTEM

Radio over Fiber (RoF) technology is proposed as a solution for reducing cost and providing highly reliable communication services [1-3]. The RoF system is very cost-effective because the localization of signal processing in central station and also use a simple base station. Radio over Fiber system realizes the transparent transform between RF signal and optical signal. Fig. 3.1 shows the scheme for the system set up. The system setup shows implementation approach for transmitting sub carrier multiplexing (SCM) encoded multiple data channels (analog and digital channels) over a bidirectional single mode optical fiber having length of 10+10 km each in uplink and downlink connections. This radio over fiber link is set up by the simulation software Optisystem™. For the downlink simulation link, a narrow bandwidth continuous wave (CW) from laser diode (having

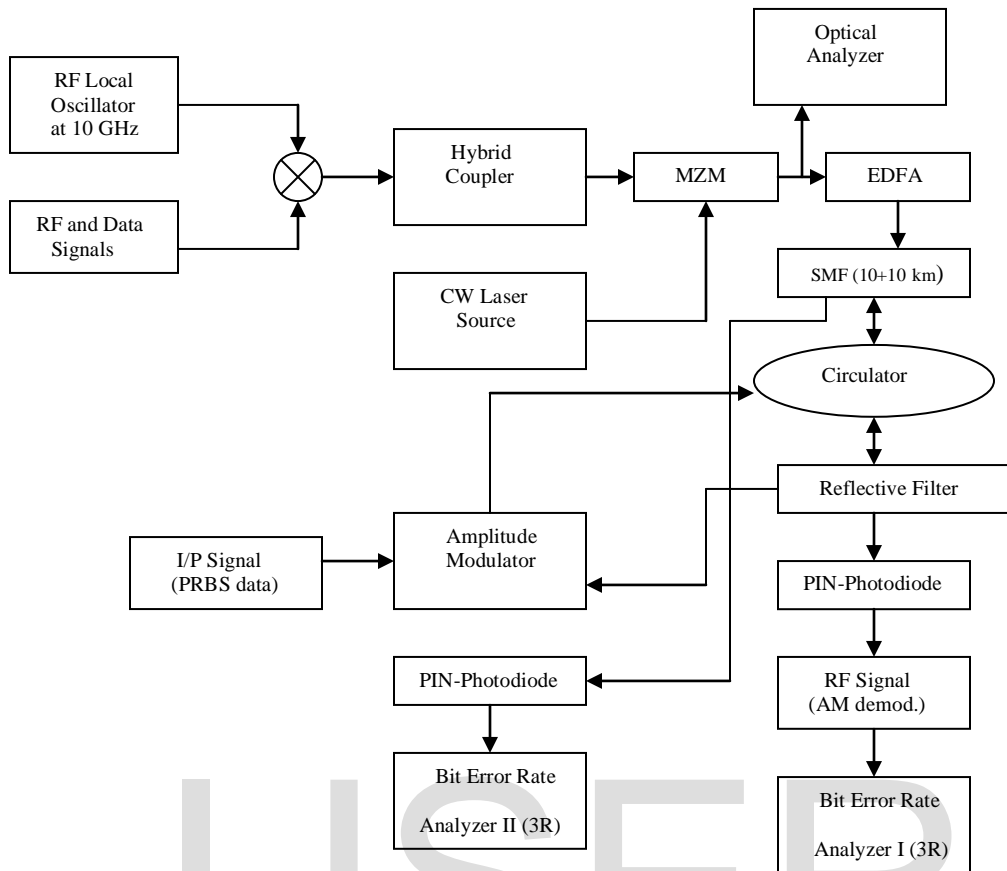

Fig 3.1 Set up for Bidirectional Radio over Fiber system

power level of 1.0 dBm and linewidth of 1 MHz and dynamic noise of 3 dB) at the wavelength of 1550 nm is modulated via a LiNbO<sub>3</sub> Mach-Zehnder modulator (MZM). The extinction ratio of MZM is 30 dB and insertion loss is 5 dB. The 10 GHz RF sinusoidal wave is amplitude modulated by pseudo-random bit sequence (PRBS) data format (NRZ) with sequence length of 2<sup>9</sup>-1. The NRZ rectangular pulse format is transmitted with pseudorandom sequence of length 2<sup>9</sup>-1. The 10 Gb/s downlink data signal with PRBS length of 2<sup>9</sup>-1 is mixed with 10 GHz local oscillator signal (sine wave) and a carrier generator having number of RF sub-carriers. The numbers of analog channels used by carrier generator are 80 at a frequency of 49.25 MHz with a channel frequency spacing of 6 MHz.

Table 1  
 Simulation Parameters for the experimental setup of RoF system

Parameter	Value
Reference Wavelength	1550 nm
Attenuation	0.22 dB/Km
Dispersion	16.75ps/nm/km
GVD parameters : $\beta_2$ and $\beta_3$	-20 ps <sup>2</sup> /km and 0.08ps <sup>2</sup> /km
PMD Coefficient	0.5 ps/(Km) <sup>2</sup>
Effective fiber core area	78 $\mu\text{m}^2$
EDFA Power	10 dBm
No. of Channels	80
Channels frequency	49.25 MHz
Frequency Spacing	6 MHz
Laser Power	1 dBm
Line width	1 MHz
PIN Responsivity	0.9 A/W

An ideal erbium-doped fiber amplifier (EDFA) pre-amplifies the optical carrier before optical to electrical conversion at the receiver section. The thermal noise of PIN-Photodiode is  $1e-22$ W/Hz. Table 1 shows the values of various simulation parameters used for the RoF system approach. The center frequency for PIN-Photodiode is 193.4 THz. A bidirectional reflective filter (Gaussian type and of 4<sup>th</sup> order) with the center frequency of 193.1 THz and having reflection of 99% is used for the simulative analysis. The optical signal sent over a single mode fiber having length of 10 km. In the receiver section, the optical signal is detected by a PIN-photodiode. PIN-PD having responsivity of 0.9 A/W and dark current 10 nA is considered at a center frequency of 193.1 THz. The signal is amplitude demodulated by an electrical amplitude demodulator having frequency of 1.7 GHz and gain of 1. At the receiver section, a band pass Bessel filter with super Gaussian of order 8, bandwidth 1GHz and insertion loss 2 dB has been taken.

The downlink microwave signal was boosted by an electrical amplifier (EA) with a gain of 15 dB and noise power of -60 dBm. For the uplink connection, the optical spectrum and waveform of the remaining optical carrier used with the help of a bidirectional reflective filter with an insertion loss 0 dB. This optical carrier was given to amplitude modulator driven by 10 Gbps uplink PRBS data with a sequence length of  $2^9-1$ . The uplink optical sidebands produce crosstalk when uplink data was detected at the control station. The crosstalk can be reduced with the help of Bessel optical filter having bandwidth of 10 GHz with depth of 100 dB. At the receiver section 3R (re-amplification, reshaping and retiming) regenerator is connected to BER analyzer, which is used to estimate the BER and Q-factor.

## 4 RESULTS AND DISCUSSION

In this section, we have analyzed and discussed the results of the simulative RoF communication model.

### 4.1 RoF system for varying optical distances

The system setup of bidirectional radio over fiber communication system is simulated for varying optical distance (from 2km to 12km) each in uplink and downlink connections. The figure 4.1 shows the optical spectrum at the central headend of the RoF system. It shows the maximum power and minimum power in dBm with a resolution bandwidth of 0.01nm at central stage. The measured values of maximum and minimum powers are 1.0147dBm and -104.81dBm at a center frequency of 193.1THz.

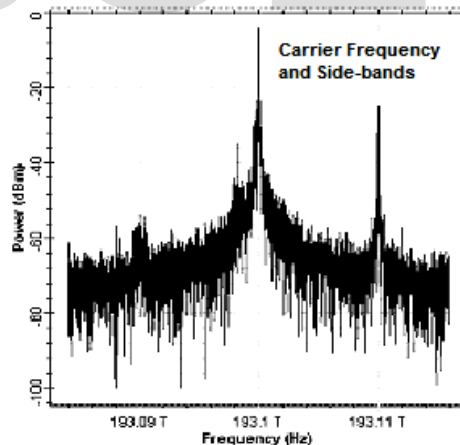

Fig 4.1 Optical spectrum at Central Station (Transmitter)

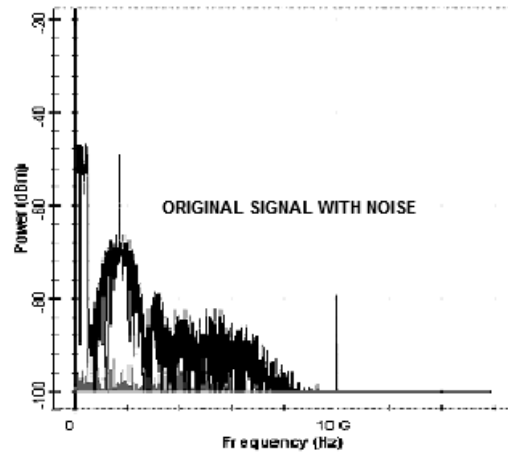

Fig 4.2 RF spectrum shows original signal with noise

RF spectrum analysis shows power vs. frequency relation for radio over fiber system in Fig 4.2. It depicts the RF spectrum analysis for signal and noise at receiving end of the radio over fiber system. The figure shows the reduction of noise level with increase in frequency.

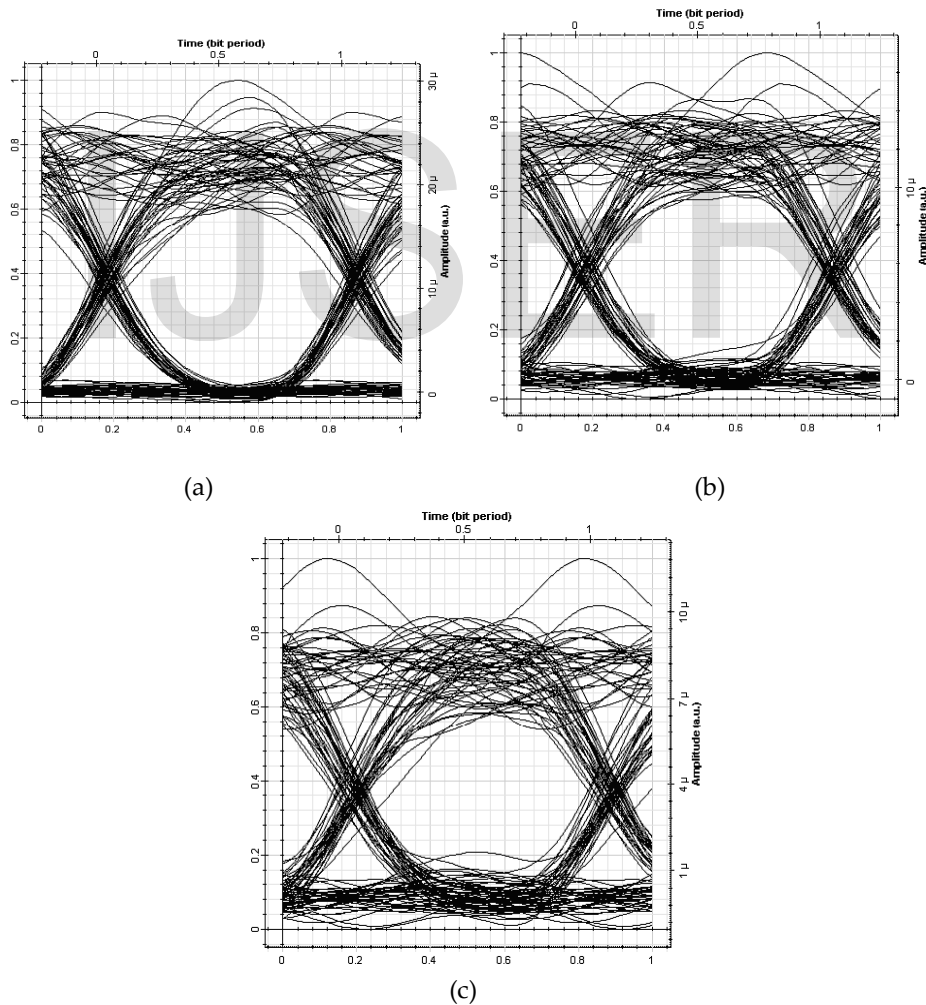

Fig 4.3 Maximum Eye amplitudes for different optical fiber of lengths (a) 2 Km (b) 8 Km and (c) 12 Km for up-linking Radio over Fiber (RoF) system.

The figure 4.3 shows the corresponding maximum eye amplitudes for different optical fiber distances. For an optical span of 2 km, eye amplitude shape is optimal than at an optical span of 12 km. The BER analysis shows that for the given radio over fiber system, the performance level degraded up to some extent when the optical fiber distance increased for fixed no. of channels and for a particular power level(in dBm) of laser diode and EDFA. This bit error rate analysis is for short/medium transmission distance (<12Km).

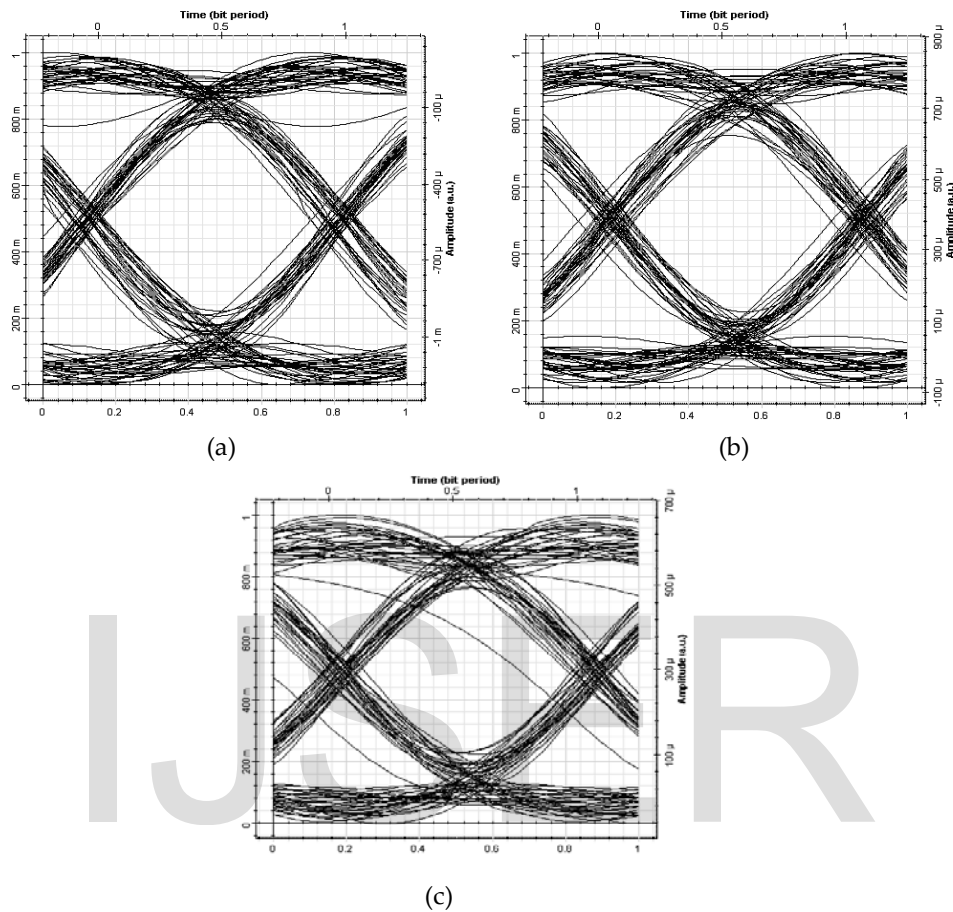
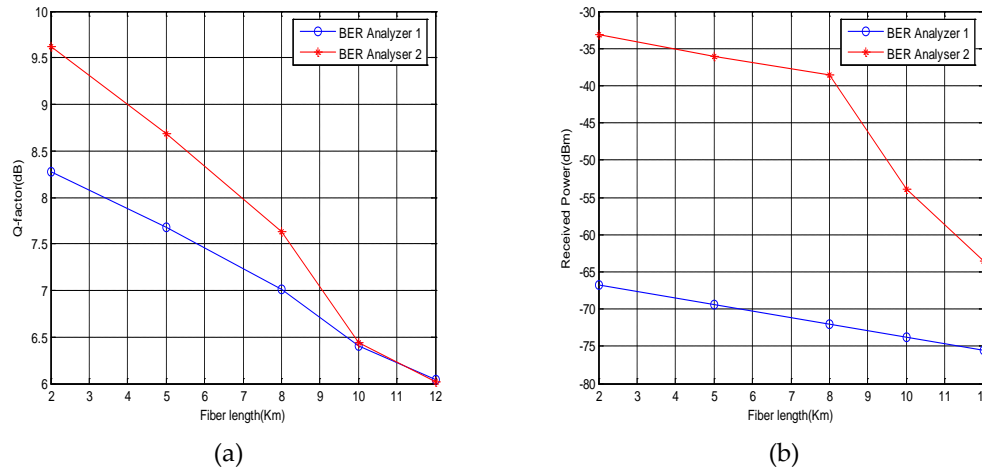

Fig 4.4 Maximum Eye amplitudes for different optical fiber of lengths (a) 2 Km (b) 8 Km and (c) 12 Km for down-linking Radio over Fiber (RoF) system

The dynamic noise for CW laser is 3dB. These results are reasonable for the direct detection scheme based on the external modulation in a medium transmission distance for a macro-cell. From the above analysis, it is concluded that there is a considerable degradation in the output signal as we increase the optical fiber length which is because of the spreading of the optical pulse, which is directly proportional to the length of fiber. The bit error rate and quality factor (Q) of the system can be increased by decreasing the power and line width of optical source (CW laser) and also by increasing the power of EDFA. For making more clarity about the performance of RoF system, we have plotted graphs showing how the different parameters like Q-factor and received power level vary according to different fiber lengths at a frequency of 193.1 THz at a bit rate of 10 Gbps with 80 channels at a constant dispersion level of 16.75ps/nm/km. These plots are shown below in figure 4.5(a) & (b).



(a) (b)  
 Fig 4.5 Comparison charts at receiver section (a) Q-factor and (b) Received Power for different fiber lengths

Figure 4.5 (a) compare the variations in the Q-factor with the optical distance for bit error rate analyzers (I) & (II). It is investigated from the figure that the Q values shows a considerable fall with the increase in the length of optical fiber. The maximum achieved value of the Q-factor for uplink connection is 9.60 dB and its minimum achieved value for downlink connection is 8.32 dB at a fiber length of 2 Km. The bit error rates for uplink and downlink connections at an optical distance of 11 km remains same. For BER analyzer (II), there is a quick fall in Q-factor after 8 km of fiber length. From 10-12 Km of fiber length, Q-factor values from both the BER analyzers superimposed. The value of quality factor approaches to 6.3 dB up to an optical distance of 11 km from the head end. Figure 4.5 (b) shows the comparison of decreasing power levels with respect to increasing optical distance for bit error rate analyzers (I) & (II). The net loss measured for the received power level is 8.79 dBm

#### 4.2 RoF system for varying dispersion values

In this case, we investigate the impact of dispersion on the performance of BER of the radio over fiber system at different dispersion levels at an optical distance of 10 km for NRZ modulation format at a bit rate of 10 Gbps. Figure (4.6) shows the results of bit error rate analyzer 1. The multiple data signals are analyzed with the help of optical and RF spectrum analyzers for radio over fiber (RoF) system. The signals are analyzed at central station and at receiving end.

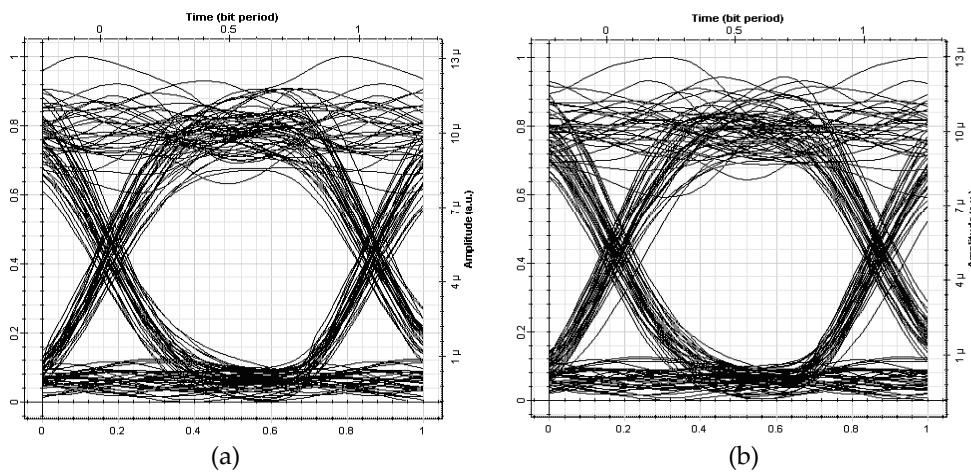



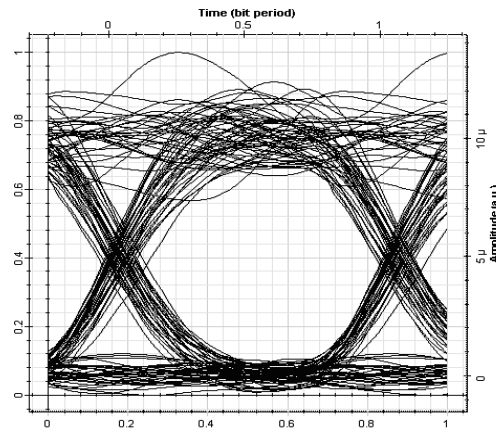

(c)

Fig 4.6 Maximum Eye amplitudes over optical distance (SMF) of 10 Km at various dispersion levels (a) 12.75ps/nm/km (b) 16.75ps/nm/km (c) 20.75ps/nm/km for up-link RoF system

The BER analysis (I) shows that for the given radio over fiber system, the performance level degraded as we increase dispersion values, pulse spreading at the peak of the eye increases, this decreases the BER of the system. Hence for single mode fibers, the results at a particular dispersion value of 16.75ps/nm/km are significant. The results obtained have been significant for an optical distance of 10 km for a medium size communication cell structure.

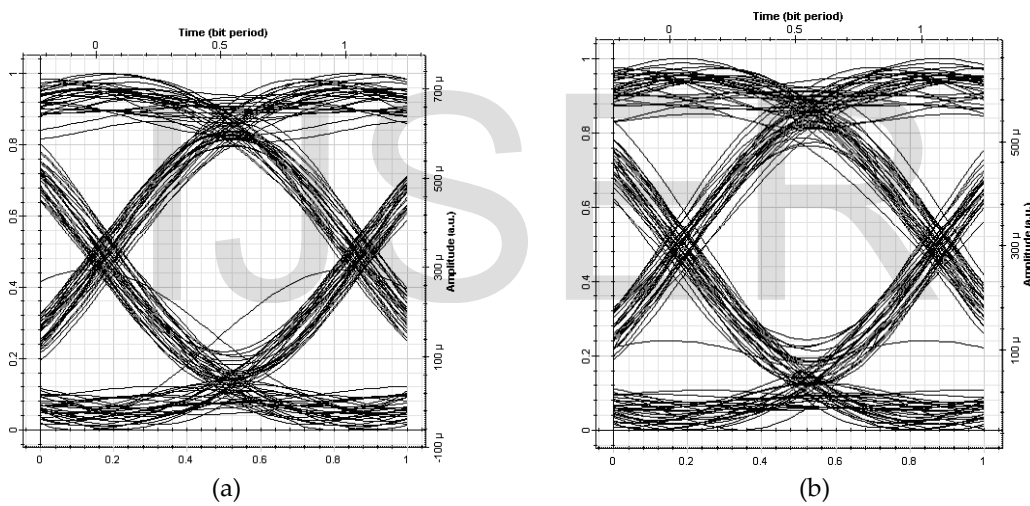

(a)

(b)

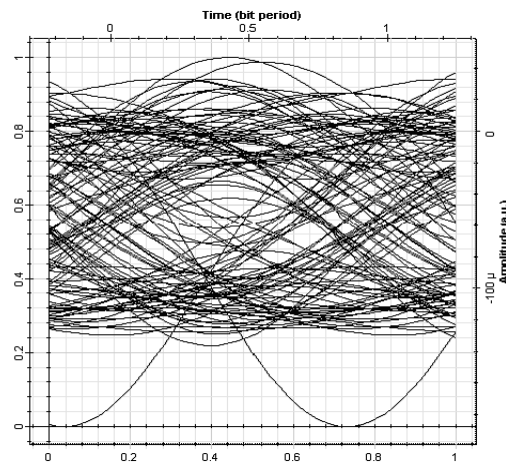

(c)

Fig 4.7 Maximum Eye amplitudes over an optical distance (SMF) of 10 Km at various dispersion levels (a) 12.75ps/nm/km (b) 16.75ps/nm/km (c) 20.75ps/nm/km for down-link RoF system.

The BER analyzer (II) shows the significant changes in the performance of the radio over fiber system for an optical distance of 10 km (single mode fiber). As the level of dispersion increases, the pulse spreading increases as shown in the figure 4.7, consequently decreases the performance BER as well as the quality factor of the system.

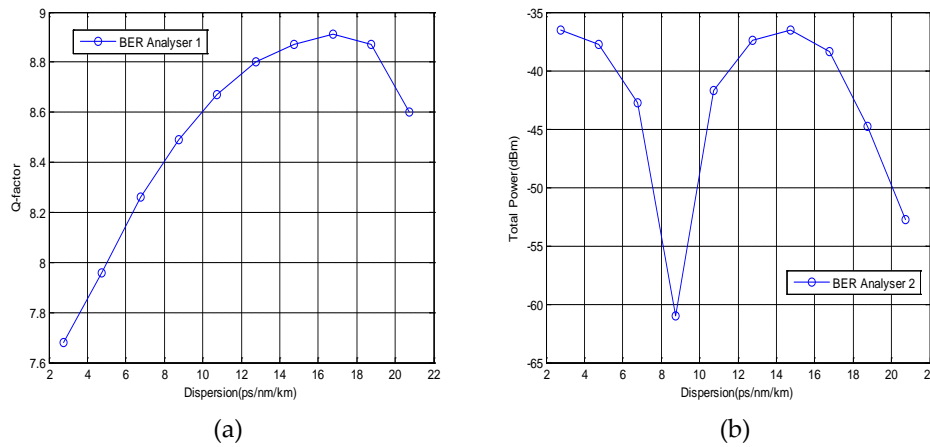

Fig 4.8 (a) Q-factor and (b) Total Received Power Plots for RoF system

Figure 4.8(a) shows the variations in the Q-factor with the different values of dispersion over an optical distance of 10 km for bit error rate analyzer. It is investigated from the figure that the Q values show a maximum value when dispersion level approaches to 16.75ps/nm/km. The Q-factor value of 8.91 dB has been achieved at dispersion level of 16.75ps/nm/km Figure 4.8(b) shows the corresponding decreasing power (dBm) level for the given dispersion values. The figure 4.9 shows the electrical constellation diagram for the simulative set up of RoF system. This diagram shows the quality of the received signal amplitude. The scattering points shows the degradation in received signal amplitude for the RoF system when number of channels N=80.

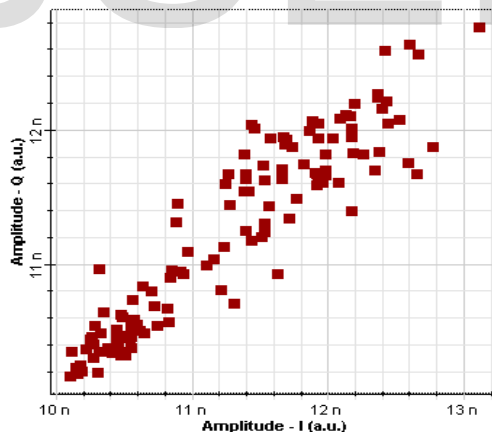

Fig 4.9 Electrical Constellation Diagram of the RoF system

## 5 CONCLUSION

This section is based on the simulative analysis model of radio over fiber system at different optical fiber lengths for the fixed no. of channels (N=80) at a constant dispersion level (16.75ps/nm/km). It has been investigated that with increasing the optical fiber distance from the central station to the base station, the performance of the resultant RF signal degraded. The BER and quality (Q) factor of the RoF system decreases. This gives to large amount of jittering. The maximal value of the achieved Q-factor is 9.60 dB for uplink connection and minimum achieved value is 8.32dB for downlink connection for RoF system at a fiber length of 2 Km. The received power level changes from -66.72dBm to -75.51dBm. Hence a total loss of 8.79dBm is measured for

the received power level. This RoF system may be suitable for the communication transmission of TV/cable, Wi-Fi and cellular signals (Wi-Max) for a macro cell having a radius of 2 to 12 km.

## REFERENCES

- [1] D. Wake, M. Webster, G. Wimpenny, K. Beacham and L. Crawford, "Radio over Fiber for Mobile Communications", pp 157-160, MWP 2004.
- [2] X. N. Fernando and S. Z. Pinter, "Radio over Fiber for Broadband Wireless Access" ADROIT Group, 2005.
- [3] Marianna Fabbri and Pier Faccin, "Radio over Fiber technologies and systems: New opportunities" pp 230-233, Proceeding, ICTON 2007.
- [4] D. Wake, "Trends and prospects for radio over fiber picocells", pp 21-24, Proc. MWP, 2002.
- [5] B. Charbonnier, H. Lee Bras, P. Urvoas, Q. T. N' Guyen, M. Huchard and A. Pizzinat "Upcoming perspectives and future challenges for RoF", pp 21-23, IEEE, Photonics, Technical Letters, 2007.
- [6] H. Harun, S. M. Idrus and A.B. Mohammad, "Optical front end receiver design for radio over fiber system", 5<sup>th</sup> SCORED, 11-12 December, 2007, Malaysia.
- [7] Andrea Casini and Pier Faccin, "Wavelength Division Multiplication technologies for UMTS radio coverage extension by using radio over fiber technique" White Paper, Andrew Corporation, Westchester, USA, 2006.
- [8] Kwansoo Lee, "Radio over Fiber for beyond 3G", pp 1-2, IEEE Tech. Letters, 2005.
- [9] G. M. Sil, H. Louchet and Andre Richter, "Efficient BER estimation for radio over fiber systems" OSA 1-55752-830-6.
- [10] X. Jin, H. Chi and X. Jhang, "Improving frequency response of radio over fiber systems by fiber Bragg grating", Electronics Letters, Vol. 42, No.6, March 2006.
- [11] A. Kaszubowska, L. P. Barry, P. Anandarajah and Ling Hu, "Characterization of wavelength interleaving in radio over fiber systems employing WDM/SCM", IEEE Tech. Letters, 2006.
- [12] Y. Li, S. M. Goldwasser, M. Bystrom and P. Herezfeld, "Generation of MSK modulated millimeter wave sub-carrier for radio over fiber applications", IEEE Tech. Letters, 2006.
- [13] Q. Chang and Yikai Su, "A radio over fiber system for simultaneous generation and transmission of multiband signals", IEEE Tech. Letters, 2005.
- [14] S. Mikroulis, A. Chipoures, S. H. Karabetsos and A. A. Nassiopoulou, "Evaluating of distributed feedback (DFB) laser operating parameters for direct modulation schemes in IM-DD RoF link", IEEE Tech. Letters, 2006.
- [15] M. G. Larrode, A. M. J. Koonen, J.J Vegas Olmas, I. Tafur Monroy and T. C. W. Schenk, "RF bandwidth capacity and SCM in a radio over fiber link employing optical frequency multiplication", IEEE Photon. Tech. Letters, 2006.